

Thank you for purchasing the **SmartStopStart GM II Auto-Stop Disable Module!** We are confident that you will be pleased with it.

Please read this important information and keep this document with your vehicle owner's manual.

SmartStopStart GM II Auto Stop Disable

Easy Installation Instructions

1. Make sure your vehicle ignition is turned off, in PARK and the doors are unlocked. Then open the trunk.
2. Remove the floor of the trunk.

Remove the Jack Stowage Retainer (1) and Spare Tire (2).

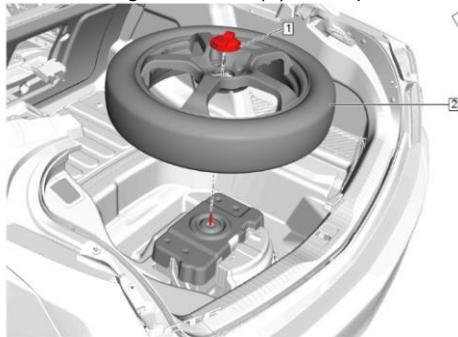

Remove the Rear Body Fuse Block Cover(2) by disengaging the tab (1)

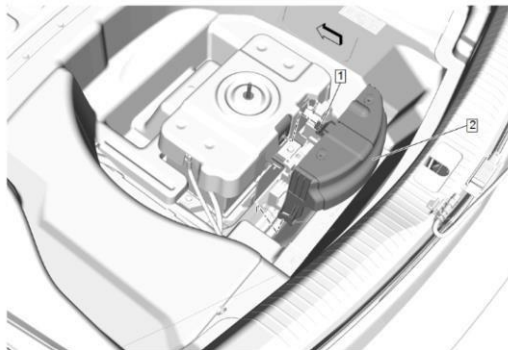

Remove the two battery cover bolts and lift off the battery cover.

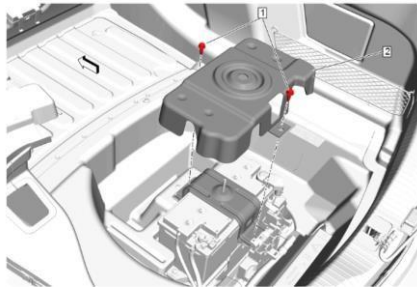

3. Locate the battery negative terminal with the battery sensor. Your battery may appear different than the photo.



4. Retrieve the 10mm nut and a 10mm wrench provided with the kit.

Place the round silver ring terminal with the black wire from the SmartStopsStart GMII module over the threaded stud with the copper base at the negative battery terminal. Screw on the 10mm nut by hand and then and **tighten the nut firmly** clockwise with the 10mm wrench.

IMPORTANT: DO NOT REMOVE THE EXISTING NUT. The new nut is applied **OVER** (TOP OF the existing nut).

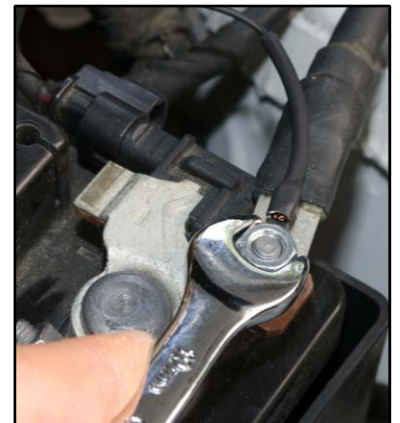

5. Locate the connector with 2 wires attached to the negative battery post. Slide the red plastic locking piece on the connector about 1/8" (3 mm) to the left until it stops.

NOTE: On some vehicles the 'red plastic locking piece' may be not be present. If that is the case, move on to the next step.



IMPORTANT: The ignition must have been **OFF** and doors **NOT OPENED OR SHUT** for **2 MINUTES OR MORE** before performing the next step.

6. Depress the black plastic lever (which is part of the connector body, just to the left of the red tab) FIRMLY with while pulling the connector shell to the left.

The connector halves will separate.

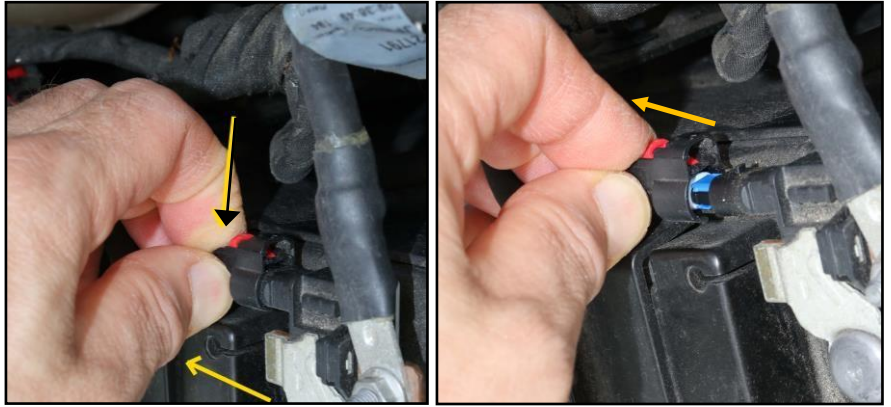

7. Now plug the SmartStopStart GM II module in between each of the two separated connector halves in the vehicle.

Push each connector pair firmly together until they engage with a click.

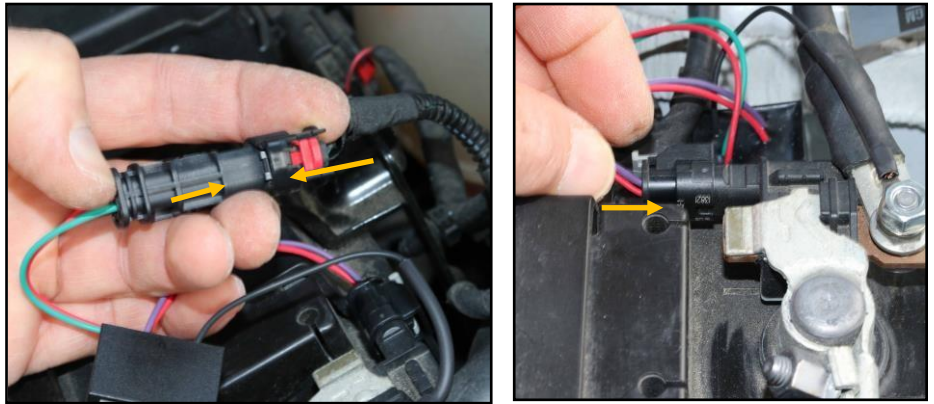

Then slide red locking piece from the original connector and the gray locking piece from the SmartStopStart GM II connector into the locked position.

8. Apply the supplied Velcro patch to the rear of the battery outer black plastic box. Press the module onto the Velcro patch.

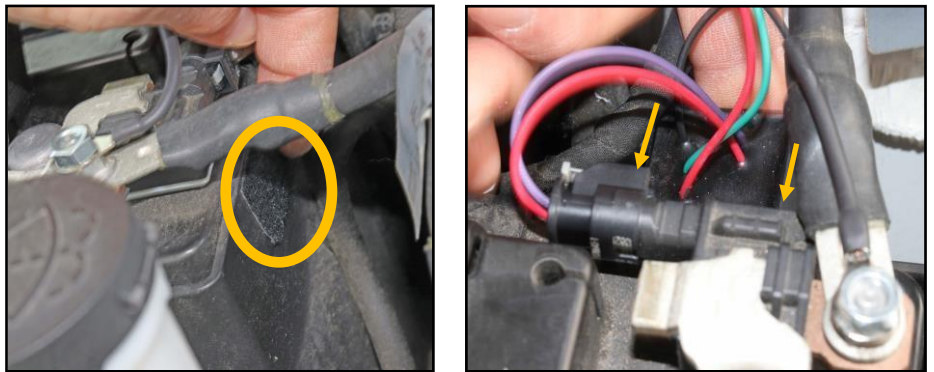

9. Use a supplied tie-wrap to secure the hanging connector body to a nearby cable.

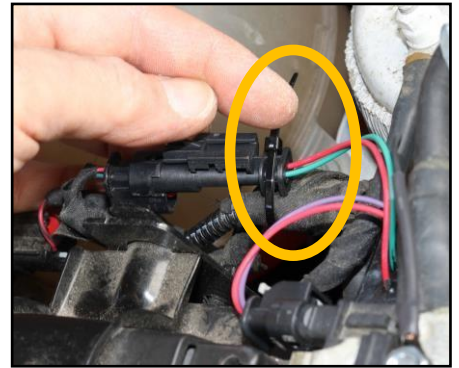

10. Reinstall the trunk floor (plus covers and spare on Cadillac CT6) and shut the trunk.

11. Installation is complete! Auto-stop will now be disabled after the vehicle is locked and not driven one time for at least 8 consecutive hours (typically overnight).

NOTE: If you need to drive the vehicle in the meantime that is OK, but the module may not work preventing auto stop until the vehicle is locked and not driven one time for at least 8 consecutive hours.

The module does not affect normal operation of the vehicle except that it will prevent the Auto-Stop feature from engaging.

Removing the module

If you ever want to restore the Auto-Stop feature, simply unplug the module and plug the original connectors back together. Then disconnect the negative terminal from the module with the 10mm wrench. The ignition must have been off and doors not opened or shut for 2 minutes or more before unplugging the module.

We suggest that you remove the module and reconnect the original connectors prior to bringing the vehicle in for service. This will avoid potentially confusing the service technician.

(Per the Magnusson-Moss Warranty Act in the US, a manufacturer or dealer can only deny a warranty claim when an aftermarket component is installed if the dealer or manufacturer can prove that the aftermarket component caused the fault in question.)

Questions? Contact: sales@zicmoto.com